



# Sabot Away!



Newsletter of the Austin Armor Builders Society

April 2026

## A Kit I Need But I Don't Have to Pay for It

By **Eric Choy**

Sometimes in life we do unexpected things. That goes with our hobby as well. It was never my intention to build ICM's 1/35<sup>th</sup> WWI Model T Ambulance. In fact, I didn't pay for the kit. It kinda fell into my lap; I drew it at a White Elephant gift exchange a few years ago. When I opened the box, I noticed some parts have already been glued together! That really pissed me off more than getting an ICM kit for Christmas. How many times have we talked about this? NO STARTED KITS!

I told myself, "Son of a motherless goat! Selling or re-gifting it is now out of the question. What do I do with this #\*&%\$ thing?" So I left it on my shelf collecting dust.

Then last year the club decided to do a group

display of military ambulances. We needed an example used in WWI. So by a strange twist of fate, this "#\*&%\$ thing" turned into "a-kit-I-need-but-I-don't-have-to-pay-for-it" thing!

### Construction

As I mentioned earlier, the donor of this kit had already built the suspension and most of the engine compartment. That just left me with the task of putting the cab together. The fit of the parts is actually quite good, but the ICM plastic is on the soft side, an indication of too much rubber and not enough petroleum?

Before assembling the cab, I painted the inside flat white according to instructions. I even experimented with

*(Continued on page 5)*

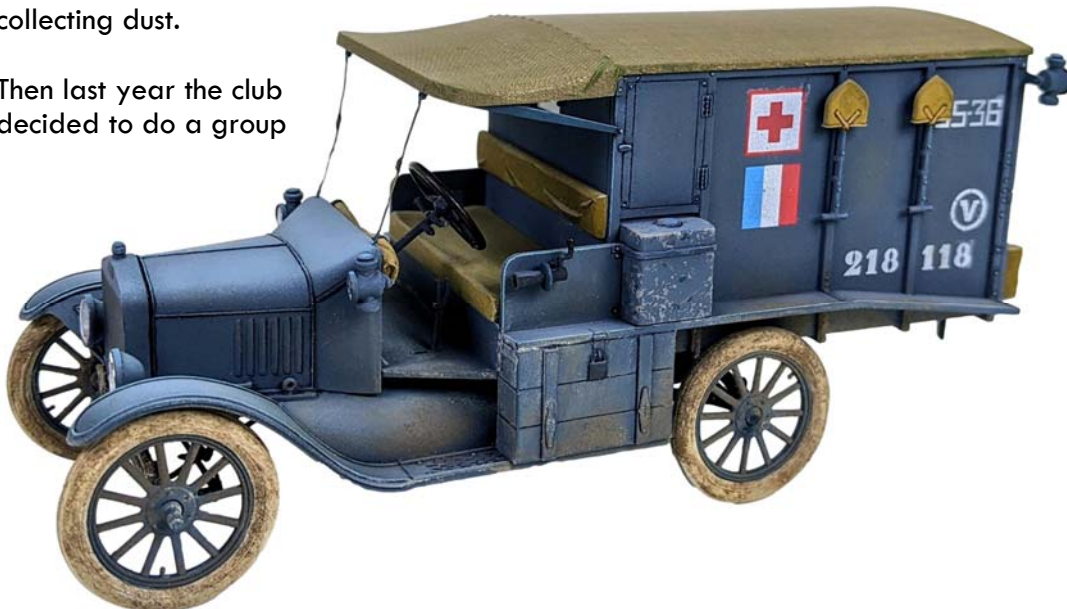

### Inside this issue:

CALENDAR OF EVENTS	2
UPCOMING PROGRAM PRESENTATIONS AND NEWSLETTER ARTICLES	2
FROM THE TURRET	3
AMPS BORESIGHT PREVIEW	7
SAHARA BREAKDOWN	8
AMPS 2026 INT'L CONVENTION	10
FEELING BLUE?	11
JOIN AMPS TODAY	12
NEW ON THE BLOCK	13
ABOUT US	13



## CALENDAR OF EVENTS

- ◆ April 1 - AABS Meeting
- ◆ April 16 to 18 - AMPS 2026 International Convention, Century Center, South Bend, IN
- ◆ May 2 - Modelmania 2026, Stafford Center, Stafford
- ◆ May 6 - AABS Meeting
- ◆ May 30 - Scalefest 2026, Grapevine Convention Center, Grapevine
- ◆ June 3 - AABS Meeting



### AABS Officers Feb 2025 – Jan 2027

**Chris Chany**, President  
christopherchany@gmail.com

**Mike Bird**, Vice-President  
mike@bartonbird.com

**Eric Choy**, Treasurer  
(512) 554-9595, aabsco@gmail.com

**Ted Paone**, Secretary  
(512) 635-9516, theopaone@att.net

**Eric Choy**, Newsletter Editor  
(512) 554-9595, aabsco@gmail.com

**Joe Fisher**, Webmaster  
(512) 350-6936,  
fisherjoe2014@gmail.com



## Schedule of Upcoming Program Presentations and Newsletter Articles

Month	Program Presentation	Newsletter Article
January ‡	Chris Chany	Ted Paone
February	Ted Paone	Mike Bird
March	Bill Zych	Bob Bethea
April	Eric Choy	Eric Choy
May ‡	Allan Romer	Allan Romer
June	* KIT AUCTION *	Christian Carrington
July	TBA	Greg Beckman
August	Craig Bland	Craig Bland
September ‡	Marty Hebda	Marty Hebda
October	Mike Bird	Mike Bird
November	* KIT-SWAP NITE *	Ron Askew
December ‡	Chris Chany	Mike Reeves
January 2027	Bob Bethea	Chris Chany

Here is a list of members who are responsible for providing articles for the newsletter and program presentation at our monthly meetings.

Please note any member may contribute as many articles as he wants at any time. The purpose of this schedule is to ensure we have at least one article in the newsletter each month.

Prompt submission of your article is much appreciated. The deadline is always **11:59PM on the last Wednesday of the previous month** (e.g. Ted Paone's article for January 2026 is due on the last Wednesday of December 2025).

‡ Quarterly contest month



*San Felipe de Austin*

## ***From the Turret***

**A**s you read this in March, our next meeting falls on April 1<sup>st</sup>. So an early April Fool's Day to you. My trip to the grandkids got moved to end of April/early May, you will have to put up with me at the meeting this month!

We don't have much business to discuss this month. Eric has the program for us. Don't forget to bring what you have been working on, and whoever won the last raffle is responsible for bringing in the prize for this month's drawing.

Here is your monthly dose of history on April 1<sup>st</sup>. First, for America 250:

1789: In New York City, the U.S. House of Representatives achieved its first quorum and elected Frederick Muhlenberg of Pennsylvania as its first Speaker of the House.

1833: The Convention of 1833, a political gathering of settlers in Mexican Texas to help draft a series of petitions to the Mexican government, began in San Felipe de Austin.

In Military History:

1865: During the American Civil War, Union troops led by Philip Sheridan decisively defeated Confederate troops under George Pickett by cutting the Army of Northern Virginia's last supply line during the Siege of Petersburg.



*Sheridan's charge at the Battle of Five Forks*

*(Continued on page 4)*

## **AABS 2026 Quarterly Contest Schedule**



<b><i>Month</i></b>	<b><i>Theme</i></b>
<b>May</b>	<b>Tamiya Kit</b>
<b>September</b>	<b>Blue!</b>
<b>December</b>	<b>White Elephant</b>

# Sabot Away!

The Newsletter of The Austin Armor Builders

April 2026 Page 4

(Continued from page 3)

1939: *Generalísimo* Francisco Franco of the Spanish State announced the end of the Spanish Civil War after Madrid fell and the last of the Republican forces surrendered.

Franco wrote on April 1, 1939:  
"The War is over."



1945: The U.S. Tenth Army began the largest amphibious assault in the Pacific Theater of World War II against the 32<sup>nd</sup> Imperial Japanese Army on the island of Okinawa.



US Marine reinforcements wading ashore to support the beachhead on Okinawa.

See you April 1<sup>st</sup>!

**Chris Chany**  
President

MODELS PAINTS TOOLS ACCESSORIES ROCKETS



"Fantastic selection and old-school feel without rejecting the new. LionHeart Hobby has built a gem in Texas!" ~Andrew T.

**VISIT OUR STORE 7 DAYS A WEEK!**

5500 FM 2770

KYLE, TEXAS 78640

(512) 504-3404

SCAN ME



www

**SHOP WITH US!**

lionheart hobby.com

**WE SHIP DAILY FROM  
OUR OWN WAREHOUSE!**



**FOLLOW US!**

@lionheart hobby

TABLETOP GAMES

PUZZLES

CHESS

RPGS

CCGS

(Continued from page 1)

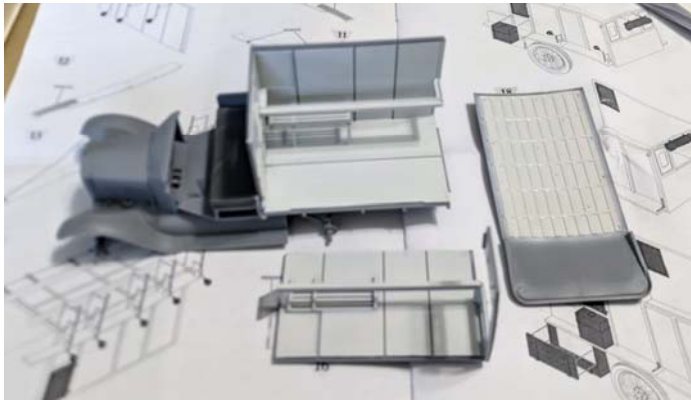

wood grain decals on the floor planks and took the trouble of masking the canvas rooftop. But then I realized very little can be seen once the model is finished, I gave up detail painting and weathering of the interior all together.



Against my better judgment, I ordered SBS Model's Model T Ambulance Update Set (35036). I ended up using a few of the PE items and very little of the resin parts that came with the set.

## Painting & Weathering

Blue is not a normal color used for vehicles in the battlefield. I reckoned it would make a nice contrast from the usual green-painted ambulances in the club's group display. Later I discovered even though the French *le drapeau tricolore* were painted on the sides of the vehicle, many French Army Model T ambulances were driven by U.S. (American Expeditionary Forces) personnel.

After priming the model with Brite-Touch General Purpose gray primer, I base-coated it with Tamiya Medium Blue (XF-18). I then added a fair amount of Light Blue (XF-23) to the base color to achieve zeiththal effect on the horizontal surfaces.

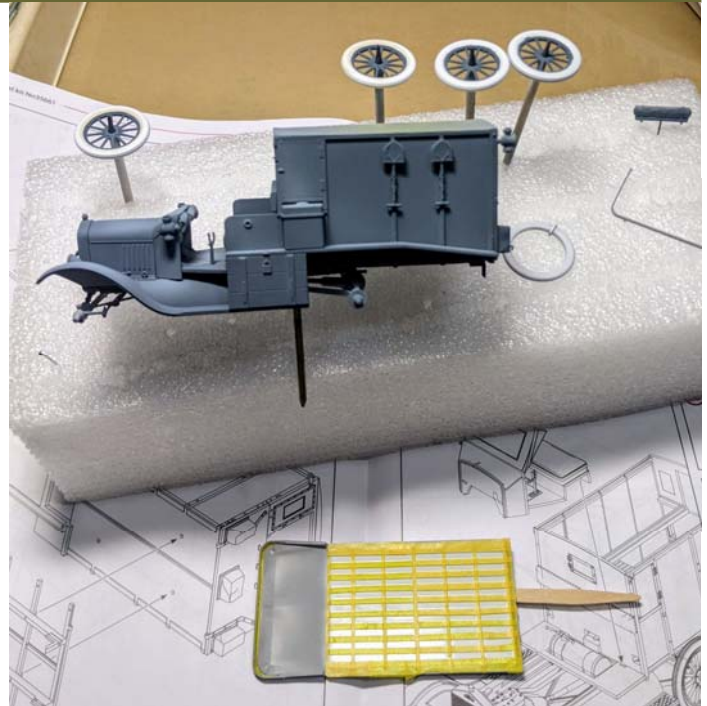

A friend of mine (aircraft modeler) suggested I give **Aviatic** linen decal a try. The decal is intended for WWI-era biplanes, and it shows a very fine texture pattern which is nearly impossible to replicate if painted by hand. I thought this could add a "wow" factor to the canvas top of my ambulance model, so I ordered a 1/32<sup>nd</sup> sheet on eBay (see photo below).

As with everything experimental, there is good and bad news. The good news is you can see the lovely thatch pattern as advertised. The bad news: the ALPS

## PC10 "LIGHT" WW1 RFC/RAF Doped Linen





printed decal does not work well with ANY type of decal softening solutions known to mankind. Also, it has a very serious, if not annoying, color shifting appearance: Olive Green under daylight-balanced lighting (color temperature of 5400K or above) but Khaki under regular indoor lights. It was near impossible to touch up the cracks I made when

manipulating the decal down flat. Should I go green or Khaki? At the end I went with green as Khaki was just too dark to my taste.

The tires were painted off-white to depict early style rubber tires that contained zinc oxide (white) instead of carbon (black) to improve durability and strength.

Since the model is for a group display, I did not spend much effort in weathering it. Just some mud on the underside and tires and a light dusting of buff-





colored enamel on the lower body. I did chip the heck out of the water container on the left fender of the vehicle.

### What Did I Learn From This Build?

1. Don't get rid of any started kit someone gives you just yet. You might find a good use for it later on.

2. Aviatic linen decal is more trouble than it's worth on any surface that has raised details. Use it on the wings of biplanes only!
3. Skip the SBS Model's T Ambulance update set! Save your \$\$\$ for a splurge at your nearest Whataburger instead!

Eric

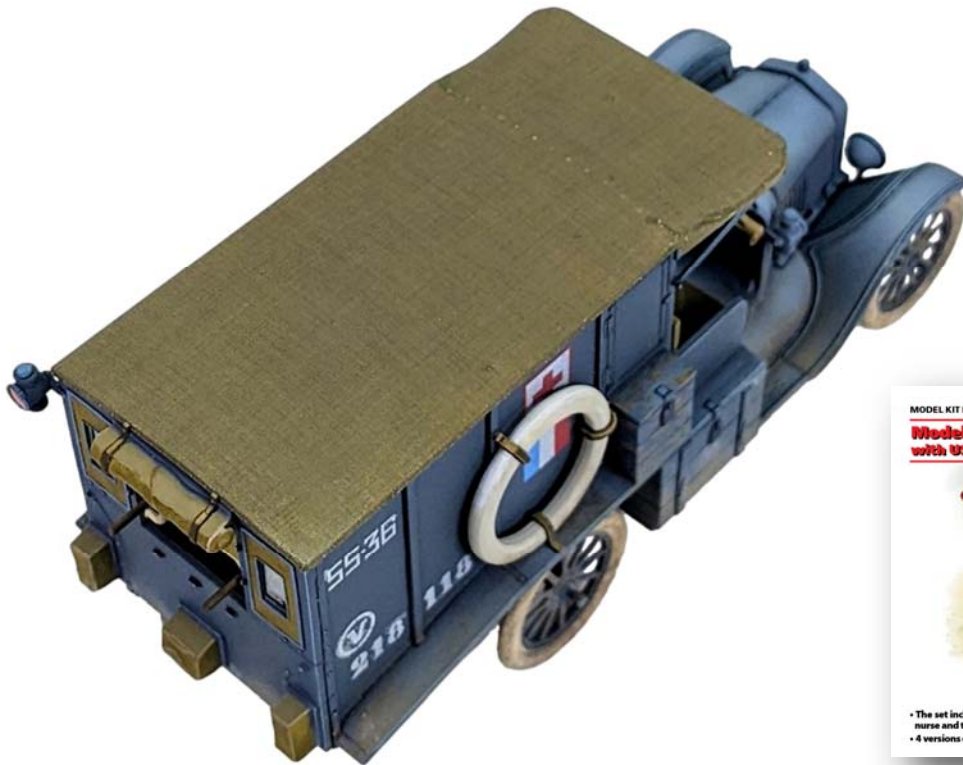

## AMPS Boresight (Volume 33, Issue 6)

The latest issue of *Boresight* is out. Here is a quick look inside:

- ◆ **Springtime in the Rockies** by Mark R. Bradley
- ◆ **Modeling the South Vietnamese Army (ARVN)** by Bill Cross
- ◆ **Christmas Carrier** by Shon Stephens
- ◆ **Hungarian StuG** by Greg Beckman
- ◆ **Book Review: Zrinyi II Assault Howitzer: Armour of the Royal Hungarian Army** by Eric Choy

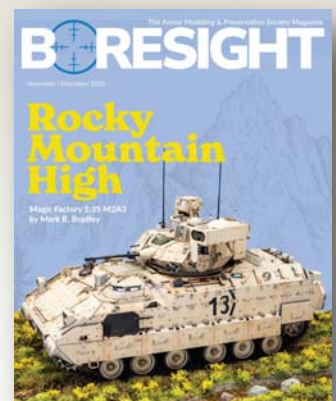



# BRaille SCALE FUN Part Deux

by Bob Bethea

# Sahara Breakdown

Decades ago I bought and built the Roden kit of the Rolls Royce Armored Car. The solid wheels made it the 1930s version rather than the wire-wheeled WW1 version. Its usage therefore would have to have been in North Africa or the Middle East. I decided to use the kit decals and make it in Egypt right before WW2.

I needed a crew, so I looked in my Preiser *Luftwaffe* set again and found a couple of guys in slacks and shirts. However, it needed more. In my search I found a set of the OLD Airfix rubber toy figures of Arabs. The sculptures were nice, but the seams cannot be sanded, so I cut them off with a sharp X-acto knife.

The idea of the diorama is two mounted Arabs finding a Rolls with a flat tire. I started with the base as I realized it would define the scene. I visualized the Rolls on the rocky flats below a sand dune. Again, I used insulation foam cut to a larger size than normal to simulate the distances in the desert and added a triangular section to the rear on which to sculpt my dune. They were glued together and





edged with balsa which hid the connection seam and was later painted black. It was covered in tile grout for texture and smoothed to simulate a dune and the rocky flats.

Spare boxes, cans, and tarps are strewn on the ground showing the effort of lightening the car before being jacked up. Putting it all together and you have another nice small diorama.

**Bob**

The Rolls was built, painted, decaled, and detailed. Next the Arabs lost their seams and were painted. The Brits had their heads swapped, arms reanimated, and new helmets sculpted. Then they were painted too.

To depict a flat tire, I had one of the tires flattened with a hot knife blade. A spare tire was drilled out and placed on the ground near the flat.



**The Armor Modeling &  
Preservation Society**



**2026 International  
Convention**



**Vietnam: Welcome to the Jungle**

**April 16-18**

**Century Center  
120 Doctor M.L.K. Jr Blvd  
South Bend, IN 46601**

**AMPS-Armor.org**

# Feeling Blue?

by  
**Mike Bird**

This month's "Feeling Blue" suggestion caters to those who enjoy building modern armor. The Type 05 family is a collection of amphibious AFVs in service with China's People's Liberation Army. The vehicles are designed to provide mobility comparable to an MBT on land as well as amphibious function.

For an out-of-the-box build, consider the HobbyBoss "PLA ZBD-05 Amphibious IFV" kit (82483) in 1/35th scale which offers two schemes that incorporate blue. Or, if you are feeling more adventurous, why not try the



striking digital camo? I wasn't able to find a decal sheet for this scheme, but I'm sure some patience and plenty of masking tape will do instead!



**Mike**

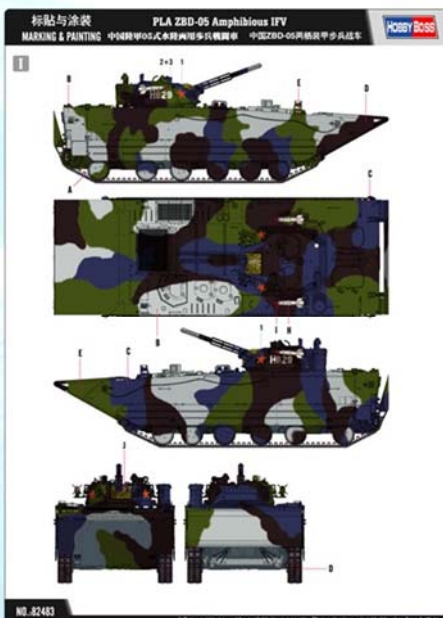

### Photo Credits:

- HobbyBoss (hobbyboss.com)
- US Naval Institute (usni.org)



# JOIN AMPS TODAY

## U.S. Membership Rates:

Type	1 year	2 years	3 years
Regular (Digital) <sup>1</sup>	\$30	\$55	\$80
Regular + All Printed <sup>2</sup>	\$55	\$105	\$155
Junior <sup>3</sup>	\$15	\$25	\$35
Family <sup>4</sup>	\$5	\$10	\$15

<sup>1</sup> Digital package includes four (4) Digital and two (2) Printed issues of *Boresight* per year.

<sup>2</sup> All Printed package includes six (6) Printed issues of *Boresight* per year.

<sup>3</sup> Juniors are members aged 17 years or younger.

<sup>4</sup> Family rates are for anyone living at the same address as an active regular member.

To join using PayPal, visit AMPS website: [www.amps-armor.org](http://www.amps-armor.org)  
-or- fill out this form below:

**NAME:** \_\_\_\_\_

**ADDRESS:** \_\_\_\_\_

**CITY:** \_\_\_\_\_ **STATE:** \_\_\_\_\_

**ZIP CODE:** \_\_\_\_\_ **PHONE:** \_\_\_\_\_

**E-MAIL:** \_\_\_\_\_

Did an AMPS member encourage you  
To join AMPS? If so, who was he/she? \_\_\_\_\_

Send completed form and check/money order to:



**AMPS**  
Attn: Membership Dept  
P.O. BOX 807, 1140 THORN RUN ROAD  
MOON TOWNSHIP, PA 15108-9998



All payments must be made in U.S. funds. For outside U.S. (Canada and International) rates, please visit AMPS website at [www.amps-armor.org](http://www.amps-armor.org).

## New On The Block



regurgitation 15 years later, the gun is now mounted on the vehicle to depict the version used by DAK in North Africa.

Not exactly a new kit per se as DML first released this 1/72nd kit in 2011 with the 2cm FlaK38 in towed position. To market this

Tamiya has just released an updated 1/35th Schwimmwagen Type 166 with wide wheel tires, and our Bob (Bethea) has already finished building it!



Not familiar with AOA Decals? That's because until recently it only offers decals for aircraft models. But now it has ventured into armor vehicles. Of interest are these two 1/35th sheets: US Army (MFO), Poland, Croatia, and Ukraine M-ATVs (35-011) and USMC JLTVs (35-013).

### About Us

The Austin Armor Builders Society (AABS) started in 1999 when Don Jones, a member of the local IPMS chapter, decided "what a good idea to get out two nights a month, and on least one night talk tanks."



AABS is the first scale model club in Central Texas devoted solely to armor modeling. We don't build planes because they are just plain! Our passion is armored fighting vehicles and military figures. Subjects of our interest range from WWI, WWII, Korea, Vietnam, Middle East, to the most recent war in Ukraine.

At each monthly meeting, we talk tanks, swap kits, and share our building techniques. We also hold regular in-house model contests and organize out-of-town trips to museums and modeling events. Every odd-numbered year, AABS hosts the biggest armor modeling show that attracts some of the best armor modelers in the Lone Star as well as neighboring states.

Since inception AABS is a local chapter of Armor Modeling and Preservation Society (AMPS), a national organization dedicated to the promotion of scale modeling and armored vehicle preservation.

For more info, please visit [www.ampscentex.org](http://www.ampscentex.org)